

2 POSTS LIFT

Operation and Service Manual

NSP3500N

OSP3500N

Dear users

Thank you for purchasing our Bishamon 2 Posts Lift. Before using the lift, read through and be familiar with this manual. Fully understand the precautions, directions, and other information contained in this manual to ensure correct use. Failure to do so may result not only in insufficient performance of the lift but also in falling of the vehicle or a personal accident.

Keep this manual in a safe place for future reference. In case of loss, immediately request a new copy.

If the product is supplied with a wrong manual, contact your dealer for a correct copy.

About maintenance inspection

Perform periodic maintenance inspections of the lift to ensure safe work with the lift and to keep the lift fully functional.

Preface

Thank you for purchasing our Bishamon 2 Posts Lift. Before using the lift, carefully read and be familiar with this manual. Carefully read the precautions, directions, and other information contained in this manual before using the lift. Failure to do so may result not only in insufficient performance of the lift but also in falling of the vehicle or a personal accident.

The contents of the manual may differ when the purchased lift is modified.

For any question about the product or this manual, feel free to contact your dealer.

Keep this manual in a safe place for future reference. In case of loss, contact your dealer immediately for a new copy.

Explanation of terms and symbols

In this manual, "Danger," "Warning," and "Caution" are defined and specified as below. Notice of Warnings is very important for safe operations. As these are very important to protect operators from accident resulting in injury and death, and damage to properties, make certain to understand fully before operating lift.

 **Danger** Incorrect operation may imminently result in serious injury or death of the operator.

 **Warning** Incorrect operation may result in serious injury or death of the operator.

 **Caution** Incorrect operation may result in injury and damage property. The possibility of occurrence of danger is lower than "Warning" articles.

Caution

DO NOT install or use a lift in a very humid place, unless the lift is intended for car

..

Table of Contents

Table of Contents	2
1 Intended use	3
2 Danger, warning, caution	3
2-1 General safety rules to be observed	3
2-2 Caution in operation	3
3. Location of the labels	8
4 Names and functions of components	9
5 Hydraulic and electric circuit	12
6 Operating principle	12
7 Safety devices	13
8 Pre-operation check	15
9 Operation instructions	16
9-1 Driving-in method	16
9-2 Setting of the supports	17
9-3 Lifting up a vehicle and stopping the lift	18
9-4 During work	19
9-5 Lowering	20
9-6 Vehicle exit	20
9-7 Miscellaneous options	21
10 Clean up after service work	22
11 Maintenance inspection	23
11-1 Leaf chain	24
11-2 Points to be lubricated	25
11-3 Restraint devices	26
11-4 Driving-side lowering stopper	26
11-5 Synchronizing chain break safety device	27
11-6 Rollers	27
11-7 Rust	27
11-8 Swing arms	28
11-9 Base	28
11-10 Chain wheel shaft	29
11-11 Hydraulic oil	29
12 Trouble shooting	30
13 Periodic replacement parts	31
14 Specifications	31
15 Installation and relocation	33
16 Disposal	33
17 Warranty	33
18 After service	34

1 Intended use

This product is a lift to be used for oil and parts replacement, general maintenance, motor vehicle inspection and maintenance, etc., of mini- to ordinary-sized passenger cars, small-sized trucks, and the like.

2 Danger, warning, caution

Caution for safety

As these are very important to protect operators from accident resulting in injury and death, and damage to cars, make certain to understand fully before operating lift.

2-1 General safety rules to be observed

1. Read and be familiar with the operation manual before operating.
2. This lift must be used only by personnel knowledgeable of its operation.
3. Make certain to perform daily and periodic inspections in accordance with the instructions of operation manual.
4. If any abnormal conditions, such as noise, occur during operation, prohibit the use of the lift and contact your dealer for an inspection.
5. This lift is designed for motor vehicle servicing. DO NOT use for any other purposes.
6. Do not remove any labels and do not modify.

2-2 Caution in operation

The meaning of the mark (symbol) used behind pictures are as below.



The specified act that should not be conducted.

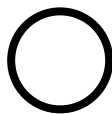

The specified act that should be conducted.



Warnings and cautions that are possible to occur due to incorrect operation.















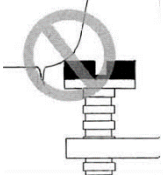





Danger



When the lift is operating, DO NOT get under vehicle.

*It may result in serious injury or death.

	<p>If a vehicle starts to fall from the lift, move away quickly. Do not attempt to support the vehicle.</p> <p>*Failure to comply may result in being crushed to death or being seriously injured under the vehicle.</p>
 Warning	
	<p>READ and be familiar with the operation manual for this lift.</p> <p>*The important warnings are described. Ignoring the warnings may result in serious accident.</p>
	<p>DO NOT use the lift unless you have been trained in its operation.</p> <p>*Incorrect operation may result in accident.</p>
	<p>Ensure that the supports are in proper contact with the specified lift points.</p> <p>*While setting the supports, be sure to stop when they come into contact with the lifting points. Then, ensure that they are in proper contact. In the event of improper contact, the supports may be dislodged, causing the vehicle to fall.</p>
	<p>DO NOT lower a vehicle with a bar or the like beneath the chassis for parts attachment/detachment.</p> <p>*The supports may be unset, causing the vehicle to fall.</p>
	<p>DO NOT swing, shake, or push the raised vehicle.</p> <p>*The supports may be unset, causing the vehicle to fall.</p>
	<p>Use genuine attachments only.</p> <p>*Failure to comply may cause vibration during lifting or work, resulting in a detached liner and falling of the vehicle.</p>
	<p>DO NOT lift vehicle by one end or by one side only.</p> <p>*It may result in falling of the vehicle and damage to the vehicle. Damage to the lift may also occur.</p>

	<p>DO NOT use the lift under an extreme offset load. Pay constant attention to the tilt of the vehicle.</p> <p>*The vehicle may fall because of vibration or parts attachment/detachment during lifting or work.</p>
 Warning	
	<p>Do not stretch your legs out under the swing arms, the carriages, or the like during lowering.</p> <p>*Failure to comply may result in being seriously injured or trapped underneath.</p>
	<p>When battery fluid is spilt on the chain, immediately prohibit the use of the lift.</p> <p>*The chain may be damaged. Be sure to replace with a new chain.</p>
	<p>A damaged chain must be replaced immediately.</p> <p>*Failure to comply may cause the vehicle to fall, resulting in a serious accident.</p>
	<p>NEVER attempt to modify any safety device.</p> <p>*Failure to comply may prevent proper operation of the safety device when necessary, resulting in a serious accident.</p>
	<p>Comply with the specified longitudinal orientation of the vehicle.</p> <p>*The vehicle may fall because of vibration, depending on its longitudinal weight distribution.</p>
	<p>Use the lift with the lowering stop hook engaged during work.</p> <p>*In case of chain breakage, the vehicle will fall. Additionally, the lift may drift down due to oil leakage.</p>
	<p>ELECTRICAL HAZARD! When the operation panel/control panel is opened, carefully avoid touching any terminal.</p> <p>*It may result in electric shock.</p>

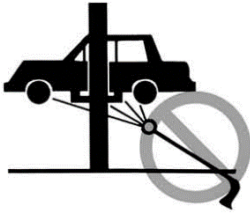

No car washing, no outdoor installation

*Water-related causes may result in faults or unexpected accidents.



Caution

Carefully read and fully understand this manual before use.

<Pre-operation check>

1. This lift is designed for motor vehicle servicing. DO NOT use for other purpose.
2. Coating, consumable parts, and the like are outside the scope of the warranty. When corrosion or wearing occurs, apply repair coating or replace the part(s).
3. DO NOT attempt to lift heavier loads than the capacity. Lift capacity is 3,500 kg.
4. If any one safety device does not operate normally, DO NOT use the lift.
5. Keep the support rubber pads' surfaces, etc., clean all the time. DO NOT use the lift with oily or dirty support rubber pads.
6. Use only genuine supports to lift up a vehicle.
7. When adjusting or retracting the swing arms or the supports, carefully avoid getting a hand or fingers caught.
8. Position Drive-on Plates under correct vehicle lifting point. If vehicle lifting points cannot be positively identified, DO NOT lift the vehicle. For the correct lifting points, refer to the maintenance manual of the vehicle.
9. When any arm is obstructed by the pinch panel, etc., of the vehicle, adjust the height of the supports before use.
10. The restraint devices do not support the weight of the vehicle or an abnormal load caused by impact.
Bring the supports into proper contact with the jack points. Failure to comply will cause an abnormal force on the restraint devices due to an offset load and supports in improper contact.
11. Adjust the height of the supports to apply load evenly to each arm. After ensuring that the restraint devices hold the arms securely, lift the vehicle.
12. The swing arms may differ in length between the front and rear sides of the vehicle. Bring the heavier side of the vehicle to the shorter arm side and the lighter side to the longer arm side.

<Lift-up/down operation>

1. When operating the lift, pay constant attention to the area around the vehicle and the lift. NEVER look aside during operation.
2. DO NOT lift vehicles with passengers or baggage inside.
3. When the support rubber pads come into contact with the vehicle during lift-up, make a halt and ensure that the support rubber pads are in proper contact.
4. DO NOT approach or touch the vehicle or the moving parts of the lift during lifting.
5. DO NOT operate the lift with anything such as tools or parts left in the posts or under the lift. Failure

to comply may result in failure of the lift or falling of the vehicle.

6. Before lowering the lift, ensure that no person or object is around the vehicle or the lift.
7. Only after the carriages are completely down, drive the vehicle onto or out from the lift. Keep the swing arms fully open to drive the vehicle onto or out from the lift.
8. DO NOT use the lift if the hydraulic pressure is released from the cylinder after lowering the lift with the lowering stop hook engaged.

<During work>

1. Make sure that safety hooks are engaged before getting under vehicle.
2. When working on a vehicle in the raised position, ensure that the lift is above the position at which the hydraulic drift prevention device is activated (210 mm or more from the lower limit position).
The lift may drift down, causing damage to the vehicle or equipment, tools, or the like nearby.
3. Keep anyone but the operator out from around the lift.
4. DO NOT leave a vehicle on the lift for a long time.
5. When not in use, the lift must be lowered to the lowest position. Even when not in use, raise and lower the lift all the way through the range at least once a day to maximize its life.

<Others>

1. DO NOT modify the lift without permission from the manufacturer. Failure to comply may result in insufficient performance and lead to a serious accident.
2. When an anomaly is detected during use or inspection, stop the lift immediately and repair the anomaly. DO NOT use the lift until the repair is completed.

Terms and definitions

“Lifting point” ... A point specified for lifting a vehicle up. For more details, refer to the maintenance manual. If no further information is available there, check with the vehicle manufacturer.

“Side sill” ... A part of the body welded to the bottom of the rocker panel. A passenger car has a lifting point on the side sill.

3. Location of the labels

Take a close look at the labels found in the following locations.

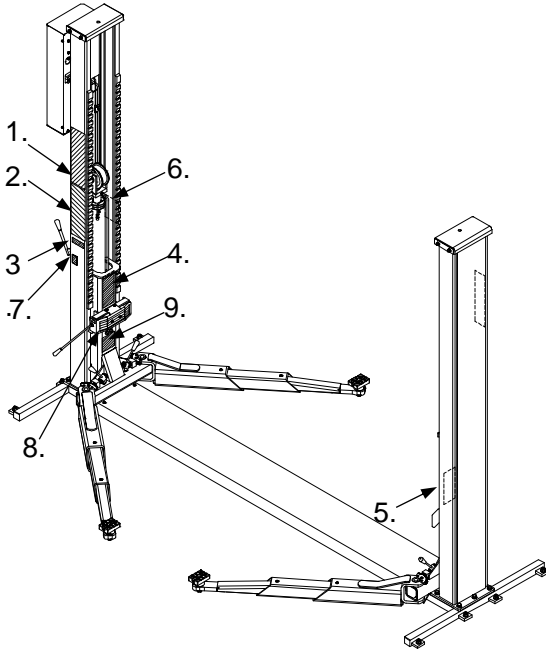

No.	Type	Remarks
1.	Danger/warning label	
2.	Caution/inspection label	
3.	Nameplate	Also indicates the lifting capacity.
4.	M-side safety device label	Used for the lowering stop hook and the chain break safety device.
5.	S-side safety device label	Used for the chain break safety device.
6.	Restraint device label	
7.	"Lift up/down" indication label	
8.	"Hook engaged/disengaged" indication label	
9.	M-side chain safety device label	

Caution

If any label is worn/damaged or peeled during use, immediately purchase and apply a new one correctly.

4 Names and functions of components

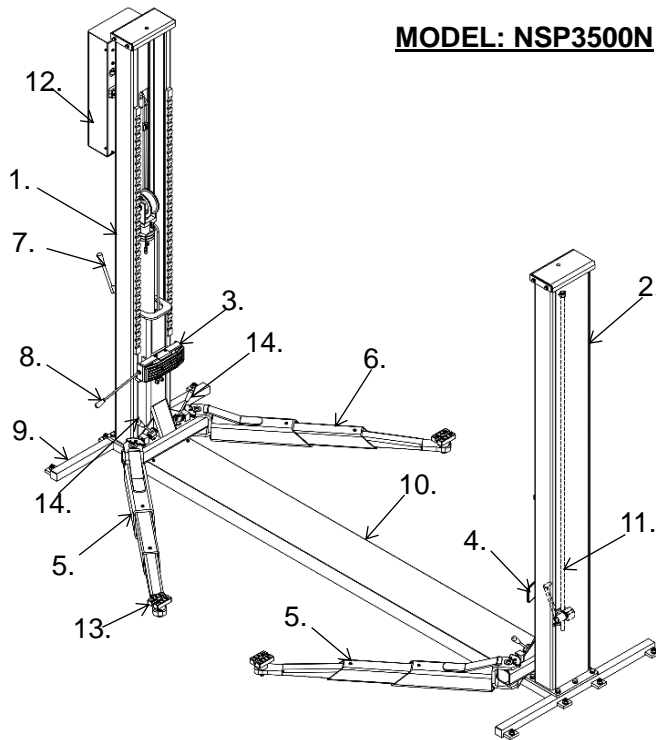

MODEL: NSP3500N

- | | |
|-----|--------------------------------|
| 1. | M post |
| 2. | S post |
| 3. | M carriage |
| 4. | S carriage |
| 5. | Swing arm (front)*1 |
| 6. | Swing arm (rear)*1 |
| 7. | Control lever |
| 8. | Hook control lever |
| 9. | Base |
| 10. | Base cover |
| 11. | Safety rod |
| 12. | Hydraulic unit |
| 13. | Support rubber pads/supports |
| 14. | Restraint device release lever |

*1 The above illustration represents a three-piece arm model. NSP37 is supplied standard with three-piece arms, while NSP30 and OSP28 are supplied standard with two-piece arms.
(Optionally switchable to three-piece arms)

■ Control lever

This lever controls the ascent and descent of the lift.

Pull the lever toward the post to turn the motor and raise the lift.

Release the lever to stop the lift immediately.

When the upper limit is reached, the lever will be forced back and the lift will stop.

Pull the lever forward to lower the lift. Note that the hook control lever must also be operated to lower the lift.

Release the lever to stop the lift immediately.

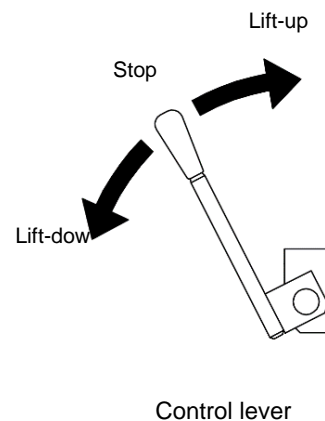

■ Safety Hook control lever

This lever disengages the lowering stop hook to lower the lift. Pull the lever to the “Disengage” side to disengage the hook and lower the lift. When the lift is lowered to the lowest position, the lowering stop hook will automatically be engaged.

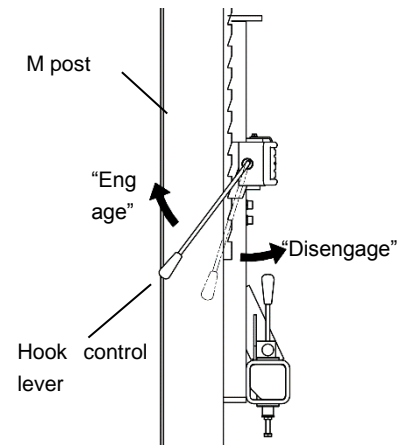

Caution

During lift-up and work, keep the lowering stop hook “engaged.” Especially when starting work with the lift halted, operate the hook control lever to “engage” the lowering stop hook.

■ Arm Restraint device release lever

This lever disengages the arm restraint device. Pull the lever to the “Unlock” side to set the arm on the vehicle lifting point, allowing the arm to swing around freely.

When returning the lever after setting the arm, the restraint device will operate to lock the arm. With the lift at the lowest position, the restraint device release lever will automatically be “unlocked.” When the lift is raised, the lever will automatically be “locked.”

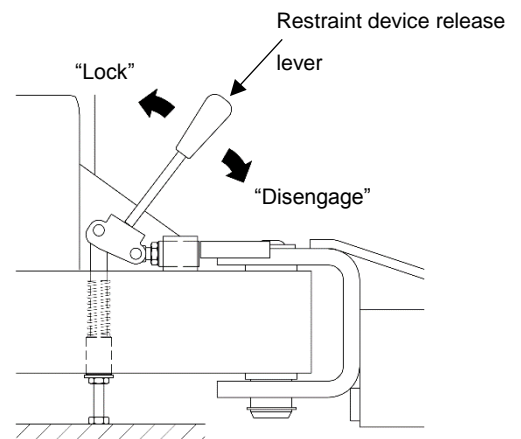

Unlocking operation



Warning

DO NOT lift a vehicle when any of the restraint devices is out of order.
The swing arms may move and dislodge the supports, causing the vehicle to fall.



Caution

The restraint devices do not support the load or impact of the vehicle.

(This device cannot prevent abnormal loads caused by offset loads or by supports in improper contact. Pay close attention to the position of the vehicle or the engagement of the supports.)

■ Swing arms

The opening angles and lengths of the arms may be adjusted to suit the lifting points for the vehicle to be lifted.

■ Supporter

Adjustable supports

These supports can be turned to adjust their heights. The supports are removable by pushing them up and hence can be easily replaced with optional frame attachments (for SUV, RV, truck, etc.).

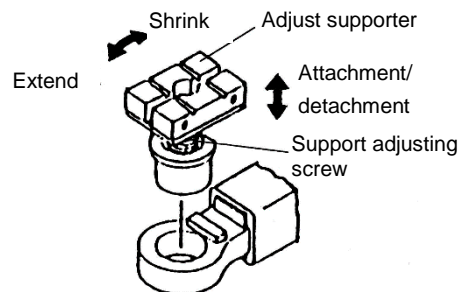

Easy attachment (optional)

A support can be raised and lowered easily just by pulling it up and by pushing its lever down.

The O-ring fitted around the slide arm insertion portion functions as a retainer for the support being pulled up.

With each side sill of the vehicle aligned with the orientation of the groove of each support rubber pad, pull the supports up to engage the side sills into the grooves of the support rubber pads.

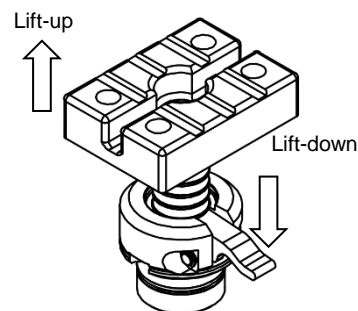

5 Hydraulic and electric circuit

Hydraulic circuit

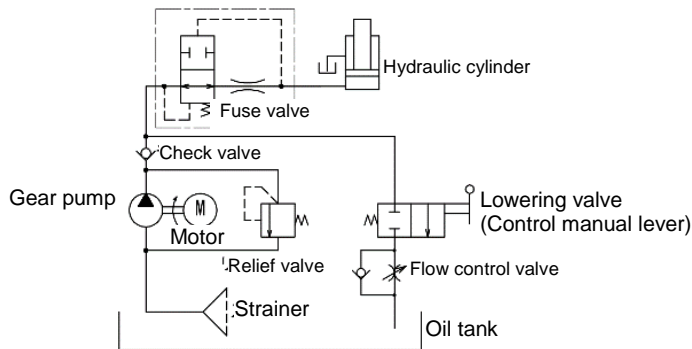

Electric circuit

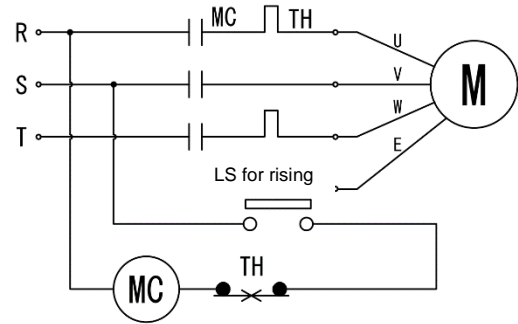

6 Operating principle

This product uses a motor-driven hydraulic pump to activate a hydraulic cylinder that raises an M carriage via a driving chain. A S carriage is connected via a synchronizing chain (driven chain) to the M carriage so that the two carriages will move up and down together.

• Lift-up

With the control lever set to the lift-up side, the motor turns and the pump feeds hydraulic oil to the cylinder to raise the carriages via the drive chain.

• Lift-down

With the control lever set to the lift-down side, the lowering valve opens to flow the hydraulic oil in the cylinder back to the oil tank through the flow stop valve, the lowering valve, and the flow control valve so that the carriages will move down.

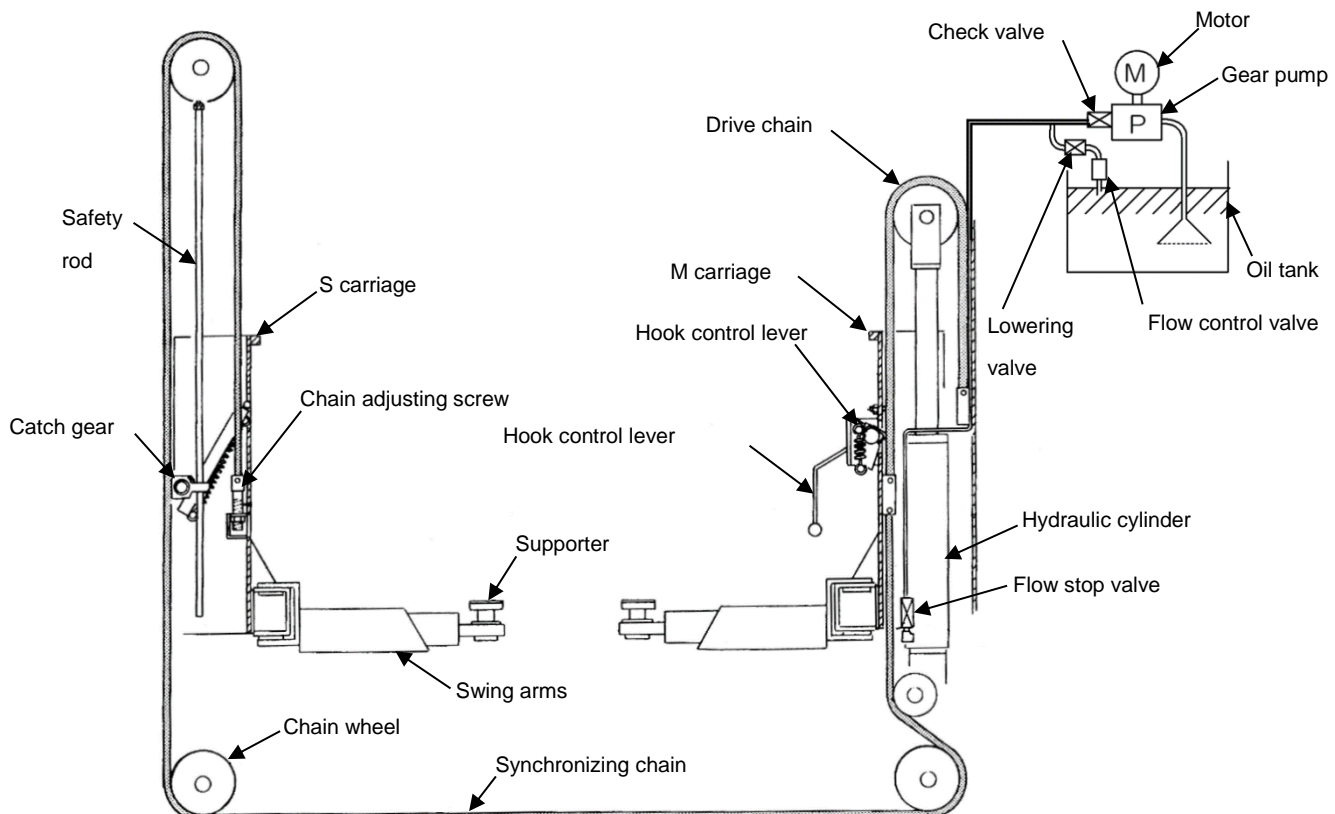

7 Safety devices

■ M side lowering stop hook and chain break safety device

Provided on the M post and the M carriage, respectively, to prevent the lift from falling in case of oil leakage or drive chain breakage. Note, however, that the lowering stop hook will be engaged only when the lift is raised up to 210 mm or more from the lower limit position.

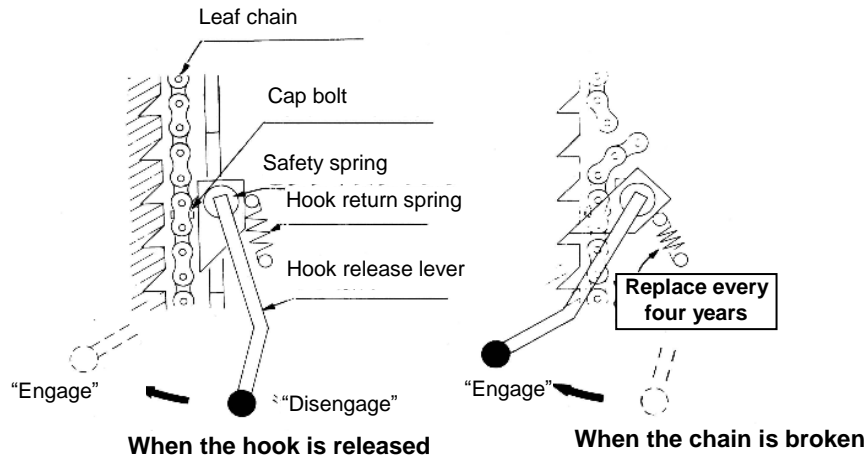

■ S side chain break safety device

Provided on the sub-post and the sub-carriage to prevent the sub-post-side lift from falling in case of the breakage of the synchronizing chain (driven chain).

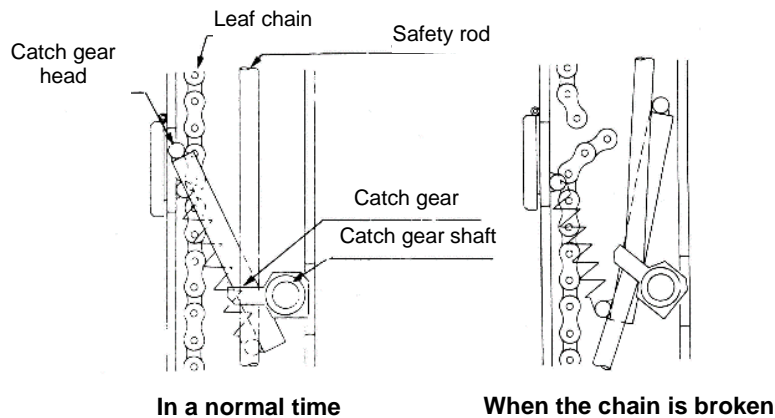

■ Fuse valve

This valve is provided on the hydraulic cylinder to prevent a rapid outflow of oil due to a cause, such as a damaged hydraulic circuit.

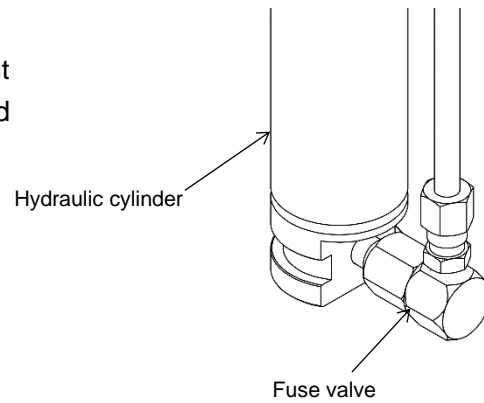

■ Relief valve

This valve releases the hydraulic pressure to prevent damage to the lift or an accident when the pressure in the hydraulic circuit increases abnormally during lift-up of a vehicle exceeding the lift capacity or due to a problem. This valve is contained in the gear pump.

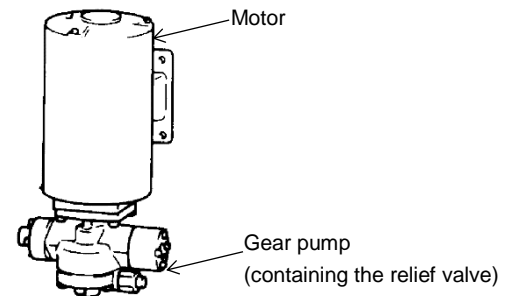

■ Thermal relay

When detecting an overload current, this relay breaks the electric circuit to prevent burning of the motor. This relay is contained in the magnet switch.

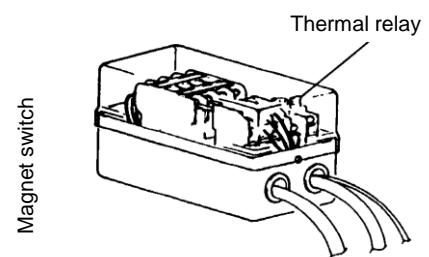

8 Pre-operation check

Perform the pre-operation checks before operation everyday. The check must be done without load.



Caution

If any possible anomaly is detected, prohibit the use of the lift until the anomaly is fully repaired. Then, contact your dealer immediately. If the lift is used with the anomaly left unsolved, damage to the lift or a serious accident may occur.

Point to be checked	Check item	Check method
Supporter	Check the support rubber pads for deformation, damage, or wear.	Visual
	Check the support adjusting screws for deformation or wear.	Visual
Swing arms Carriage	Check for deformation.	Visual
	Check the restraint devices for normal operation.	Visual/operation
	Shake to check for excessive play.	Shaking
	Check the swing arms for height differences.	Visual
Main body	Check for smooth lifting. Check the sliding parts for foreign matter.	Visual
	Listen for abnormal noise.	Hearing
	Visually check the body for damage/distortion.	Visual
Control lever	Check for smooth operation.	Hearing/operation
	Check if the lever surely returns to the neutral position.	Visual
Lowering stopper	Listen for the noise (chattering) made by the lowering stop hook during lifting.	Hearing
	Check the hook control lever for normal operation.	Visual/operation
Hydraulic circuit	Check the hydraulic piping, the cylinder, and the hydraulic unit for oil leakage.	Visual/feeling
	Listen for abnormal noise.	Hearing
Bolts/screws	Check for tightness.	Retightening
Leaf chain	Check for foreign matter such as dirt or sand.	Visual
Electric circuit	Check that proper earthing is provided.	Visual

9 Operation instructions

9-1 Driving-in method

1. Spread the four swing arms open toward the posts and drive a vehicle in between. Drive the vehicle in to match the center of the vehicle width direction with the center between the two posts.
2. Stop the vehicle so that its center of gravity will be on the line connecting the centers of the two posts or within the range illustrated below. For the center of gravity of a specific type of vehicle, refer to its maintenance manual.

Warning

If the center of gravity of the vehicle is outside the range shown below, the vehicle may lose balance and fall while lifted up. Be sure to stop the vehicle so that its center of gravity will be within the range shown below.

<Drive-in method for OSP3500N>

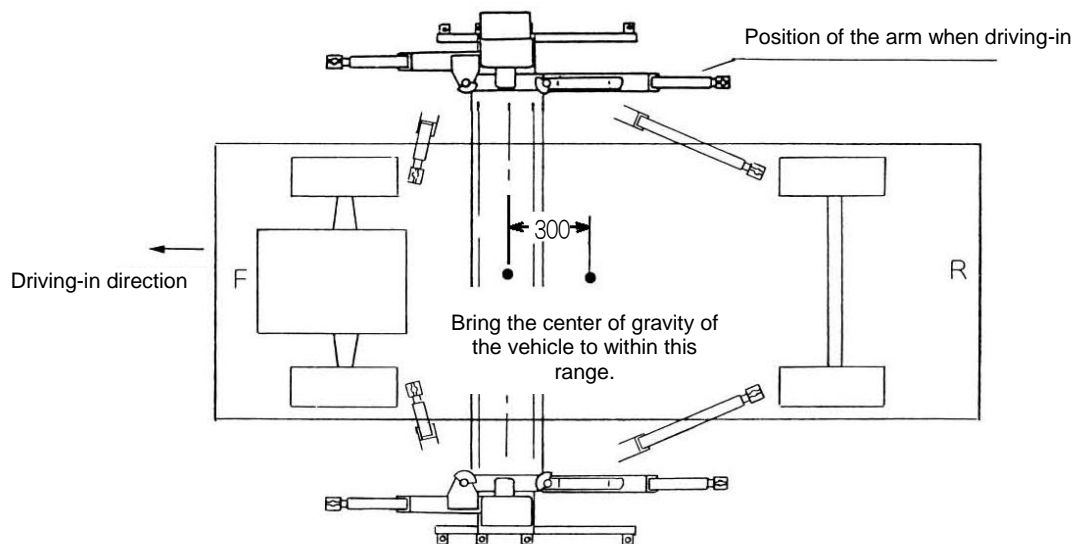

<NSP3500N>

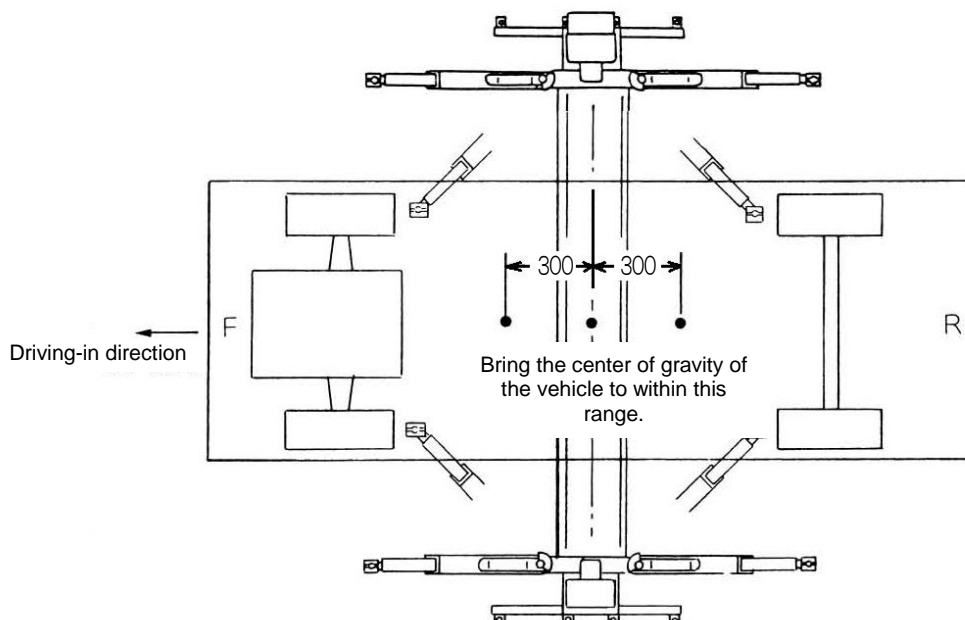

9-2 Setting of the supports

1. When in the lowest position, the swing arms can be swung around freely. Swing, extend, and retract the swing arms for adjustment so that the supports will reach the correct lifting points to suit the vehicle.



Caution

For the correct lifting points of a specific model of vehicle, refer to its maintenance manual.

2. Turn the supports and adjust the height of each support rubber pad to lift up the vehicle horizontally, to apply load evenly to all the four supports, and to push the support rubber pads to the lifting points.



Warning

*Use the lift with the height of the four supports adjusted to apply load evenly to them.
Under uneven load, the supports may be dislodged, causing the vehicle to fall.

*Be sure to set the supports to the correct lifting points.

If not set securely, the supports may be dislodged, causing the vehicle to fall or be damaged.

*Any damaged or worn support rubber pad must immediately be replaced with a new one.

Failure to comply may cause the support to be dislodged, resulting in falling of the vehicle.



Caution

*In some types of vehicles, the parts below the doors are likely to be hit by the swing arms, etc.

In such a case, set the support adjusting screws to proper height before use.

*Spread the swing arms as wide as possible before use.

*To lift up an RV or a small truck, use dedicated frame attachments. An attempt to lift up such a vehicle using the supports for passenger car may cause the supports to be dislodged, resulting in falling of the vehicle.

■Reference■

In the case of a passenger car, the lift is usually used with the support rubber pads pressed on the side sills (welded mating faces) in the lower part of the body. Use the lift with each side sill engaged in the slot in each support rubber pad.

9-3 Lifting up a vehicle and stopping the lift

Danger

*Keep out from under the vehicle during lift operation.

*If the vehicle is falling from the lift, move away quickly. **DO NOT** attempt to support the vehicle.

Caution

***DO NOT** lift up a vehicle with any person or baggage inside.

*Pay constant attention to the area around the vehicle and the lift during lift-up. **NEVER** look aside during operation.

1. Pull the control lever to the lift-up side and lift up the vehicle until the support rubber pads come into contact with the lifting points. Then, ensure that the positions of the adjustable supports are matched with those of the lifting points. If not, readjust the positions of the adjustable supports.

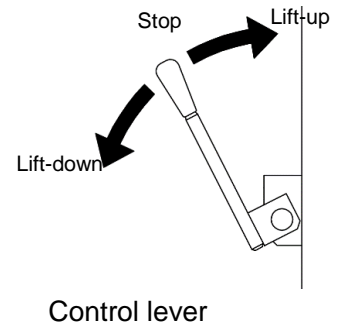

*When the lift is raised, the restraint devices will automatically be engaged.

If the swing arms need to be swung around after the lift is raised, pull the restraint device release lever to disengage the restraint devices.

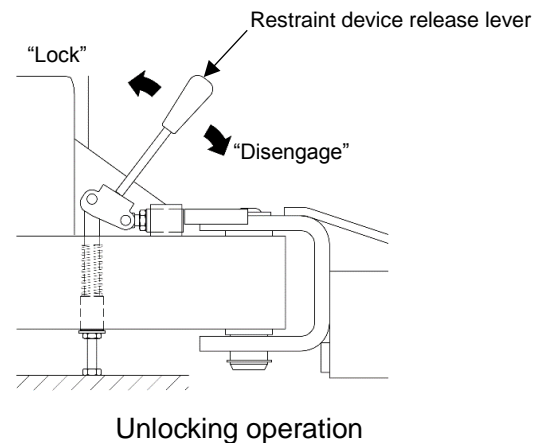

Warning

DO NOT lift a vehicle when any of the restraint devices is out of order.

The swing arms may move and dislodge the supports, causing the vehicle to fall.

Caution

The restraint devices do not support the load or impact of the vehicle.

(This device cannot prevent abnormal loads caused by offset loads or by supports in improper contact. Pay close attention to the position of the vehicle or the engagement of the supports.)

2. If the adjustable supports are correctly positioned, lift up the vehicle until its tires are slightly off the floor. Slowly shake the vehicle with care to ensure that the supports are engaged and that the vehicle is well-balanced.
3. After ensuring the restraint devices are engaged and that the vehicle is level front to rear and side to side, push the control lever to lift the vehicle up to the desired height. During lift-up, listen for rattling sounds made by the hydraulic drift prevention device.
4. Before starting work, ensure that the lowering stop hook is engaged.

Warning

Keep the lowering stop hook “engaged” during work.

Caution

*Perform work with the lift raised up to a height at which the lowering stop hook is activated.

Note that the lowering stop hook will not be activated when the upper surfaces of the supports are approximately 350 mm or less from the floor.

*DO NOT use the lift if the hydraulic pressure is released from the cylinder after lowering the lift with the lowering stop hook “engaged.”

*The chains will be elongated more or less under load.

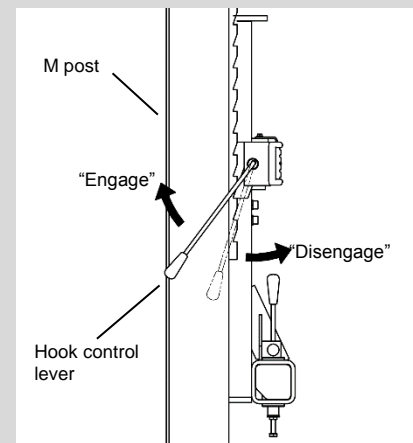

9-4 During work

Danger

If the vehicle is falling from the lift, move away quickly. DO NOT attempt to support the vehicle.

Warning

DO NOT swing, shake, or push the raised vehicle.

Caution

*Keep anyone but the operator out from around the lift.

*DO NOT leave a vehicle on the lift for a long time.

*Before starting work, ensure that the lowering stop hook is “engaged.”

9-5 Lowering

Danger

***Keep out from under the vehicle during lift operation.**

***If the vehicle is falling from the lift, move away quickly. DO NOT attempt to support the vehicle.**

1. After ensuring that there is no object left under the vehicle to be lowered, set the lowering stop hook to the “Disengage” position.
2. Pull the control lever gently to the “lowering” side to lower the vehicle.

Caution

***Be sure to “engaged” the lowering stop hook again before making a halt during lift-down to perform work.**

***If the hook control lever cannot be pulled to the “Disengage” side, the lowering stop hook may be engaged. In this case, raise the lift slightly once and**

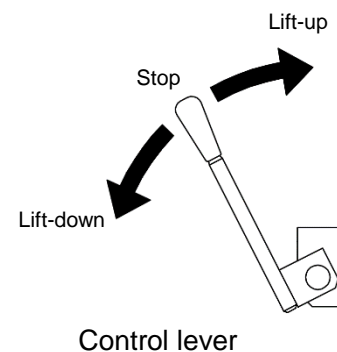

9-6 Vehicle exit

1. Lower the lift to the lowest position and spread the four swing arms as wide as possible.

Caution

***The contact of the vehicle tires with the floor will not result in automatic disengagement of the restraint devices unless the lift reaches the lowest position.**

***Lower the lift to the lowest position before swinging the swing arms around.**

2. Drive the vehicle out.

9-7 Miscellaneous options

■ Frame attachments

In the case of a vehicle with lifting points on its frame, such as an RV or SUV, use the frame attachments. Select from four types to suit the application.

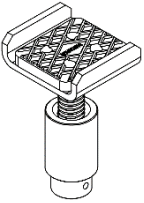
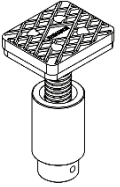
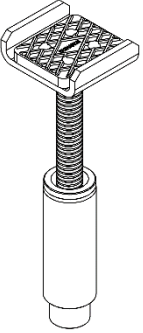
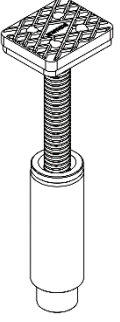
			
LA	LB	HA	HB
With guards	Without guards	With guards	Without guards
169 to 233 mm*		256 to 430 mm*	

*Measurement from the floor to the top surface of the support.

■ Adjust supporter

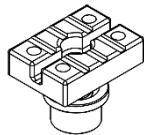
	
Adjust supporter (standard)	Adjust supporter S
121 to 161 mm*	97 to 117 mm*

Usable for low-profile vehicles.

*Measurement from the floor to the top surface of the support.

■ Easy attachment

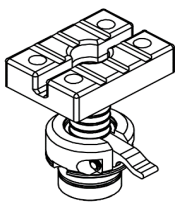
121 to 167 mm*

A support can be raised and lowered easily just by pulling it up and by pushing its lever down.

*Measurement from the floor to the top surface of the support.

10 Clean up after service work

After completing work, wipe any oil or grease off from the supports or the lift area.

Air-blow all parts of the lift sufficiently to remove moisture, dirt, etc.

Eliminate moisture or dirt from around the lift. If any anomaly is detected, contact your dealer immediately for advice. To ensure safety, lower the lift to the lowest position and turn the power off (circuit breaker).

11 Maintenance inspection

To ensure safe use, be sure to perform monthly maintenance inspection in addition to daily pre-operation inspection.

The check must be done without load.

Caution

If any possible anomaly is detected, prohibit the use of the lift until the anomaly is fully repaired. Contact your dealer immediately for repair. If the lift is used with the anomaly left unsolved, damage to the lift or a serious accident may result. Always use Bishamon genuine parts for repair.

Point to be checked	Check item	Refer to
Leaf chain	Check for rust, kinks, and cracks.	11-1
Points to be lubricated	Lubrication	11-2
Restraint devices	Check for normal operation.	11-3
Driving-side lowering stopper	Check for normal operation.	11-4
Supporter	Support rubber pads and adjusting screws	Check for damage and/or wear.
Driven chain break safety device	Check for normal operation. Check the safety rod for scratches.	11-5
Rollers	Rotational wear on guide rollers and side rollers	11-6
Rust	Check for rust and apply repair coating as necessary.	11-7
Swing arms	Plate thickness, deformation, and drooping	11-8
Hydraulic system	Cylinder and hydraulic unit	Check for oil leakage.
Base	Tightness of bolts	11-9
Chain wheel shaft	Tightness of bolts	11-10
Hydraulic oil	Hydraulic oil replacement	11-11

Make pre-operation checks in addition to the above checks.

Caution

Wear protective gear as necessary before starting inspection.

Important safety instructions

In addition to the above maintenance inspection, a lift must undergo periodic inspection by a specialist once a year.

Contact your dealer for periodic inspection.

11-1 Leaf chain

Warning

Even before the end of the replacement interval, replace the chain immediately if battery fluid is spilt on it or if any rust, bend, or crack is detected on it. If any anomaly is detected, prohibit the use of the lift. Resume use only after the anomaly is fully repaired.

1. Lubrication

Check the surface for tear or for any red or dark brown portion. ⇒ Apply lubricant.
(Recommended type of oil: lubricant (oil) with viscosity of SAE 30 to 40)

2. Plate check

Check plates for cracks in hole rims or side faces.
⇒ If any crack is detected, replace the chain.



Places to be cracked easily

3. Pin check

Check pins for rotation.
⇒ If any rotation is detected, replace the chain.

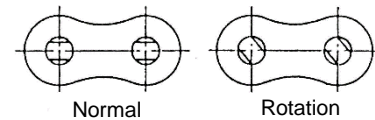

4. Elongation check

Ensure that the chain has an elongation of 2 percent or less.

Using vernier calipers as per the right figure, measure the outer and inner lengths L1 and L2 between the outermost pins in the section where the chain bends over the chain wheel. Then, obtain the determining length $L = (L1 + L2)/2$.

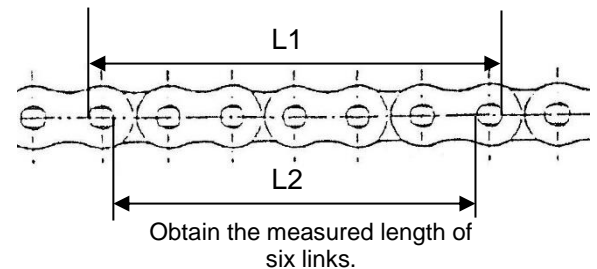

	1-link length	6-link length	Limit determining length
Drive chain (chain above cylinder)	25.4 mm	152.4 mm	155.5 mm
Driven chain (chain between posts)	19.05 mm	114.3 mm	116.5 mm

⇒ If the elongation is 2% or more (equal to or greater than the limit determining length), replace the chain.



In principle, replace the chain every four years or when used more than 8,000 times.
Contact your dealer for chain replacement.

11-2 Points to be lubricated

<Lubrication/greasing>

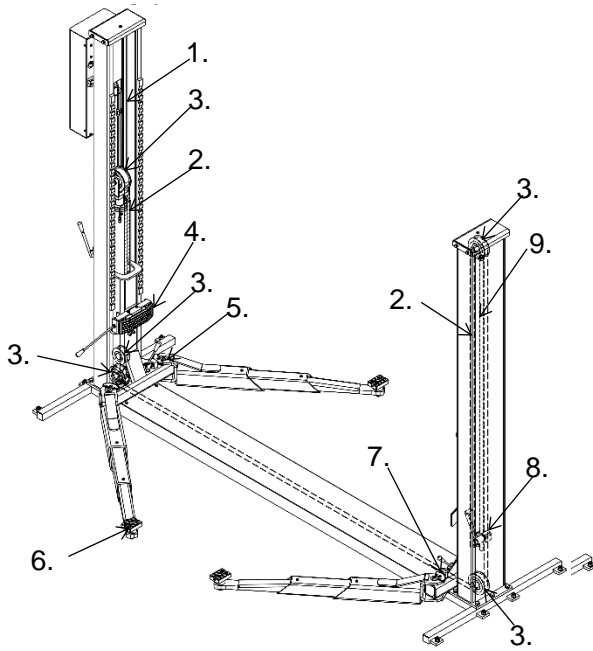
*Use lithium base grease.

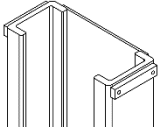

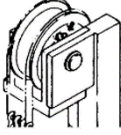
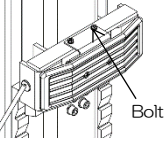
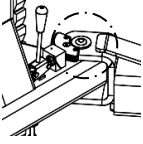
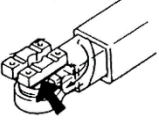
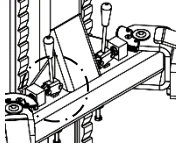
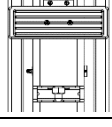
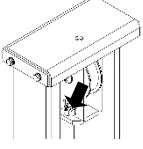
Points to be lubricated	Type	Lubrication method
1. Inner surface of the post 	Grease	Apply grease all over the inner surface of the post from top to bottom, using a brush or the like.
2. Leaf chain 	Oil (SAE30 to 40)	Lower the lift to the lowest position so that the leaf chain will be slackened. Then, apply oil so that it will enter the gap between the outer circumference of the chain and the plate.
3. Chain wheel 	Grease	Use a grease pump to inject grease into a grease nipple on each chain wheel or each shaft. (4 points)
4. Hook control lever 	Grease	Remove the bolts mounting the door bumper and apply grease to the spring and the shaft inside, using a brush, etc.
5. Arm pin 	Oil	Apply oil to the contact surface between the arm pin and the swing arm.
6. Adjusting screws 	Grease	Apply grease to the adjusting screw of each support, using a brush or the like.
7. Restraint devices 	Grease	Apply grease to each restraint device handle/shaft, etc., using a brush or the like.
8. Driven chain break safety device 	Grease	Using a grease pump, inject grease into the grease nipple on the catch gear shaft.
9. Safety rod 	Grease	Apply grease to the safety rod tip screw, using a brush or the like.

11-3 Arm Restraint devices

1. Bring the lift to the lowest position to ensure that the restraint devices are unlocked, allowing the four swing arms to swing around smoothly.

⇒ If the restraint devices are not unlocked, adjust to give 1 to 2 mm clearance (“A” in right figure) to the lock rods with the carriages at the lowest position.

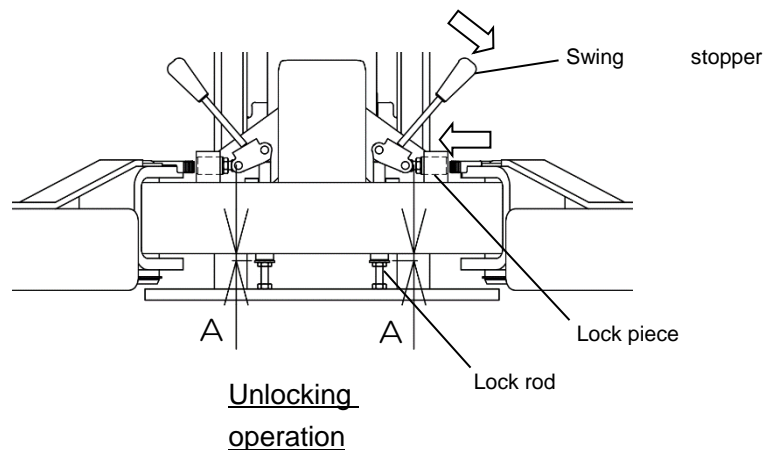

2. Raise the lift by 50 mm or more to ensure that the restraint device lock gears are meshed with the lock pieces, preventing the four swing arms from swinging around.

⇒ If the lock gears and the lock pieces are not meshed well, the cause may be a worn part(s) or poor adjustment. Replace the part(s) or adjust the mesh between the lock gear and the lock piece. Adjust the adjusting nut as per the right figure.

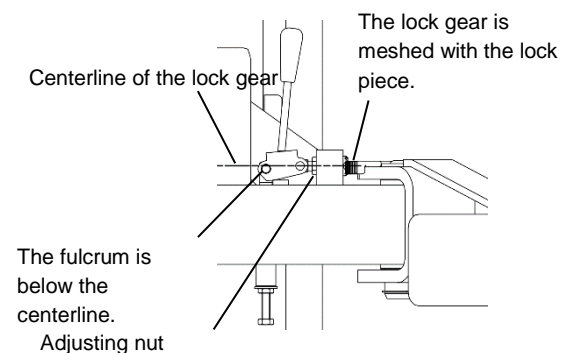

3. Check the tightness of the mounting screw for the swing arm lock gear.

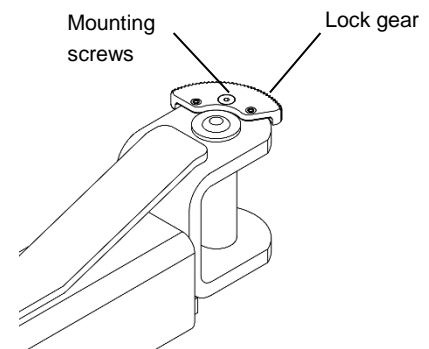

11-4 Driving-side lowering stopper

1. Raise the lift to ensure that the lowering stop hook is “engaged,” making a rattling noise. (Daily check item)

2. Disengage the hook control lever to lower the lift to the lowest position. Then, ensure that the chain is slackened to “engage” the lowering stop hook.

3. If the chain fails to hold itself under no load condition, the cap bolt or the safety spring may be worn and should be replaced immediately.

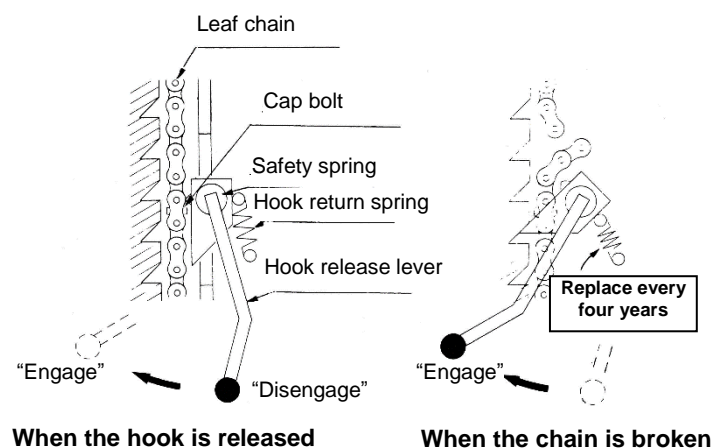

11-5 Synchronizing chain break safety device

1. Periodically apply grease to the catch gear shaft.
2. Check the safety rod for scratches or bends. Replace the safety rod if scratched or bent.
3. Ensure that the catch gear head is at the normal position on the chain.
4. Periodically apply rustproof grease to the leaf chain.
5. Periodically check the catch gear for normal function.

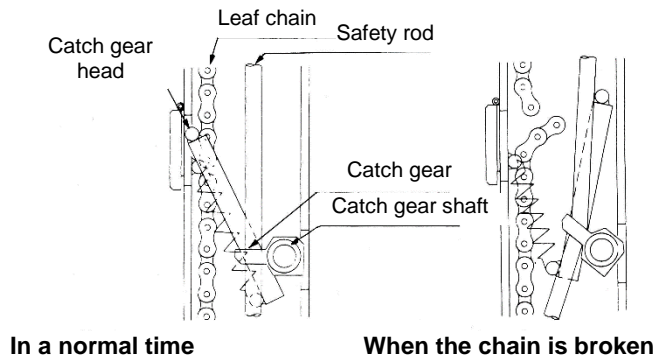

Method of checking the operation of the catch gear

1. Remove the safety rod from the catch gear.
2. Raise the lift slightly under no load condition. Place a wood board under the driven carriage and lower the lift.

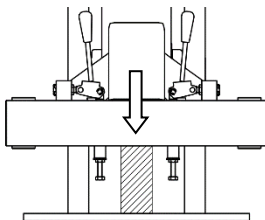

3. Slacken the chain to check the catch gear for smooth rotation.

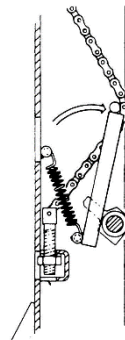

4. If no tilt occurs smoothly, replace the catch gear, the catch gear shaft, and the spring immediately.
5. Be sure to replace the safety rod back into the catch gear after the check or replacement. If anything has gone wrong due to failure to comply with this, the safety device will fail to operate, resulting in a serious accident. Replace the safety rod back into the catch gear without fail.

11-6 Rollers

1. Check for smooth rotation. Check for wear.

11-7 Rust

1. Check for rust.
⇒ If any rust is detected, remove it and apply repair coating.
Carefully check the posts, the carriages, and the arms.

11-8 Swing arms

1. Fully draw out the slide arms to ensure that the stoppers work and that the stopper bolts are sufficiently tightened.
2. Check for foreign matter, rust, or the like that prevents normal sliding.
3. Check the lift arms for thickness.
 - ⇒ Replace the arms if their thickness is smaller by 20% from the standard value.

		Standard thickness	Limit thickness
1. Two-piece long arm	Dimension A	6.0 mm	4.8 mm
2. Two-piece short arm	Dimension B	6.0 mm	4.8 mm

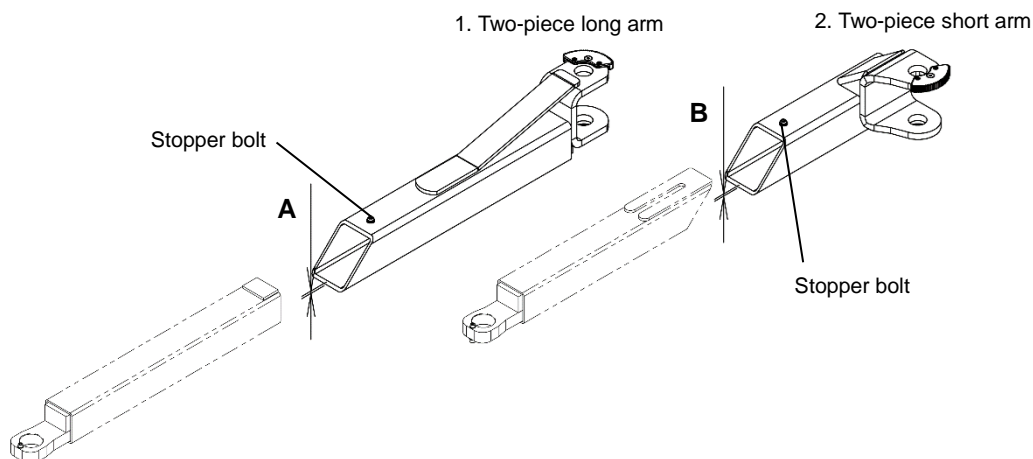

11-9 Base

1. Retighten the anchor bolts with a torque of 100 N·m.
2. Check for swells, cracks, or any other defects in the floor surface around the anchor bolts.
3. Retighten the bolts (M16) securing the posts to the bases with a torque of 250 N·m.

11-10 Chain wheel shaft

1. Check the tightness of the chain wheel shaft securing bolts.

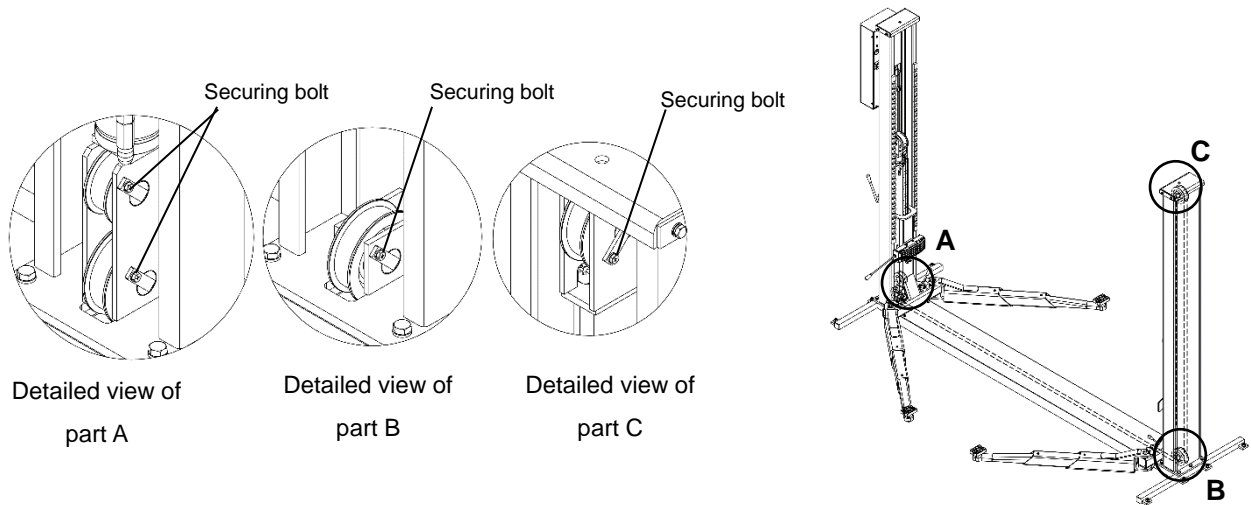

11-11 Hydraulic oil

<Hydraulic oil replacement>

1. Replace the hydraulic oil one year after start of use. From the second time and on, replace the full amount every three years.

Replacement method

1. Remove the hydraulic unit cover.
2. Remove the drain plug (arrowed in the right figure) from the bottom of the oil tank to drain the hydraulic oil.
After drainage, replace and tighten the drain plug securely.
3. Remove the top lid from the oil tank to check the condition of the suction filter. A dirty or rusty filter must be cleaned, replaced, or otherwise appropriately treated.
4. Fill the specified amount (8 liters) of hydraulic oil from the top of the oil tank.
5. Raise the lift to check for normal operation.

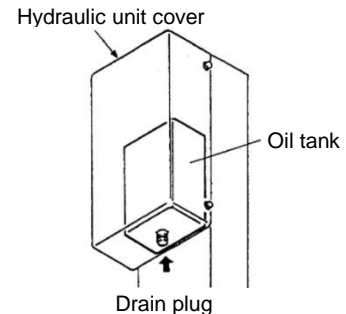

Note that this product uses a gear pump, the performance of which is significantly affected by the hydraulic oil used. Be sure to select an appropriate brand from the table below.

Viscosity grade ISO VG32 Wear-proof hydraulic oil (amount to be used: 8 liters)

Idemitsu	Super Hydraulic Fluid 32	JX Nikko-Nisseki	Super Hyrando 32
ESSO	Nuto H 32 Unipower SQ 32 and XL32	Mobil	Mobil DTE Oil 24
Showa Shell	Terrace Oil 32 and K32		

Caution

- *Use extreme care to avoid touching any high-voltage parts during inspection.
- *After performing inspection with the cover and associated parts removed, replace them back in place using all mounting screws.
- *If an inspection reveals any anomaly, immediately prohibit the use of the lift and contact your dealer for corrective action.

12 Trouble shooting

If a fault is suspected, make a second check.

If any anomaly occurs, carefully read this manual and make the following checks. If the anomaly persists, contact your dealer for advice.

Symptom	Possible cause	Action
Lift does not rise.	<Motor does not rotate> <ul style="list-style-type: none"> - Power cable improperly connected or broken. - Magnet switch thermal relay activated. - Primary-side circuit breaker tripped. 	<ul style="list-style-type: none"> - Check the cable for connection and continuity. - Identify the cause and push the reset button. - Reset the primary-side circuit breaker.
	<Motor rotates> <ul style="list-style-type: none"> - Motor turns in the wrong direction. - Lack of oil - Overload 	<ul style="list-style-type: none"> - Replace the R- and T-phases of the power cable. - Fill the oil - Normal. A vehicle exceeding the lift capacity cannot be lifted up.
Lift drifts down.	<ul style="list-style-type: none"> - The lift drifts down at the rate of 1.0 mm/5 min or less. - Hydraulic oil leaking from piping. - Hydraulic oil leaking from cylinder. 	<ul style="list-style-type: none"> - Within the tolerable range and normal. - Retighten the piping. - Replace the cylinder packing.
Lift moves up too slowly.	<ul style="list-style-type: none"> - Overload 	<ul style="list-style-type: none"> - The lift capacity is almost reached. Check the weight of the vehicle.
Noise	<ul style="list-style-type: none"> - Lack of oil - Little grease on sliding surface of post. - Piping not secured properly. - Cover not secured properly. 	<ul style="list-style-type: none"> - Fill the oil - Lubricate the specified point(s). - Re-secure the piping properly. - Re-secure the cover properly.

Warning

Before performing any electrical work, be sure to turn off the power supply.

13 Periodic replacement parts

Replace the following parts periodically to maintain the safety of the machine and to prevent faults and other problems.

*The replacement intervals do not show the warranty period of the parts.

Depending on the operating conditions and environment of the machine, the listed parts may have to be replaced before the specified timing and parts not listed here may have to be replaced.

Contact your dealer for replacement of non-consumable parts.

Replacement interval	Part name
Once a year	- Attachment rubbers
Every three years	- Oil (one year after installation and then every three years)
See 11-1 on page 23.	- Leaf chain

14 Specifications

NSP3500N

Type	NSP3500N
Capacity	3,500kg
Vertical travel	1,800 mm
Operation	Lever operated
Power supply	3 PH/220/380/415 V 50/60 Hz
Lifting motor	1.5 kW 4P/10 min. Rating
Lifting speed	Approximately 59 seconds (60 Hz) Approximately 70 seconds (50 Hz)
Hydraulic oil	ISO Standards: VG32 Hydraulic oil
Hydraulic oil volume	8 L

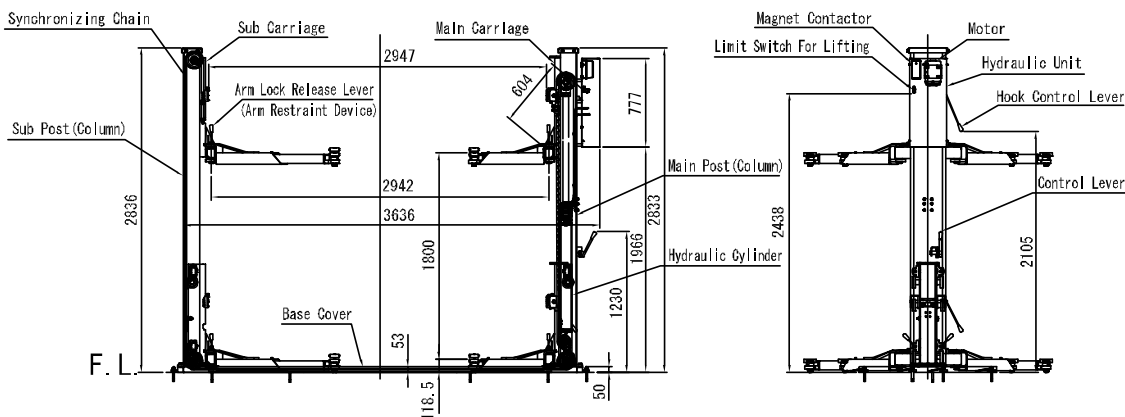
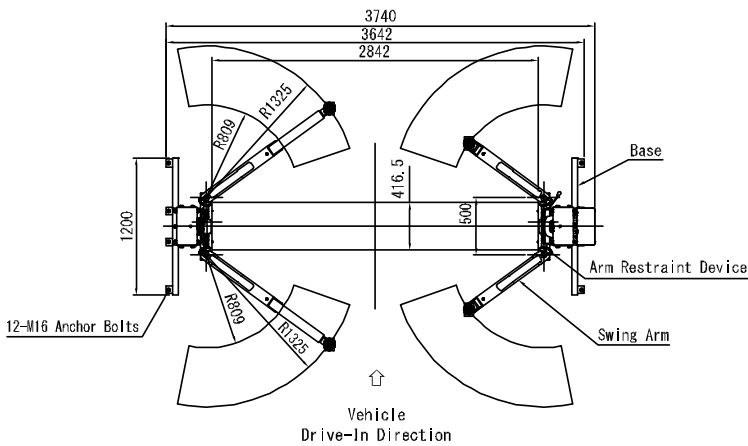

OSP3500N

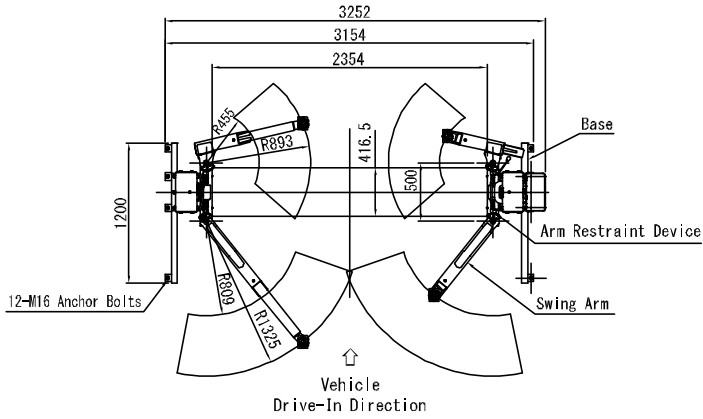

Type	OSP3500N
Capacity	3,500 kg
Vertical travel	1,800 mm
Operation	Lever operated
Power supply	3 PH/220/380/415 V 50/60 Hz
Lifting motor	1.5 kW 4P/10 min. Rating
Lifting speed	Approximately 59 seconds (60 Hz) Approximately 70 seconds (50 Hz)
Hydraulic oil	ISO Standards: VG32 Hydraulic oil
Hydraulic oil volume	8 L

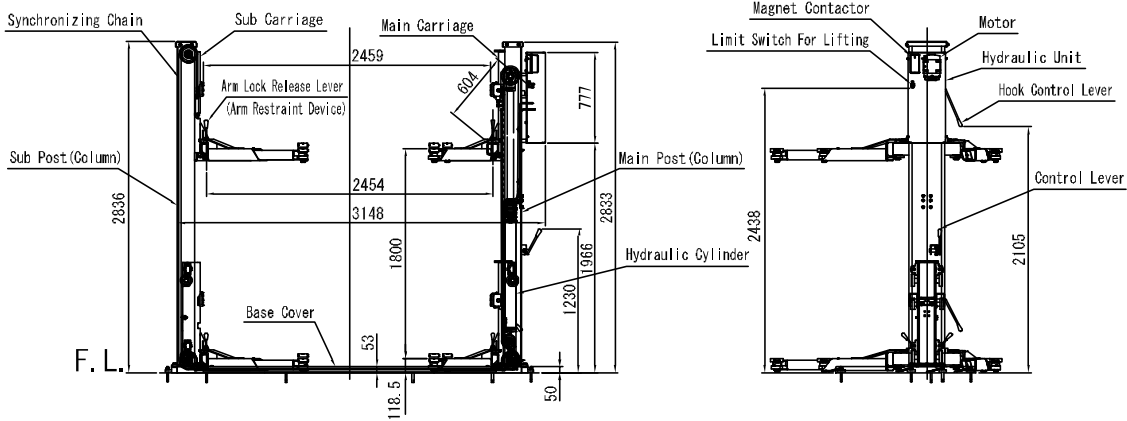

*The above specifications are subject to change without prior notice for improvements.

15 Installation and relocation

Contact your dealer for the installation and relocation of this product.
Have your lift inspected by the dealer before relocation.

16 Disposal

When disposing of this product, break it down into scrap and separate the scrap into steel, non-ferrous metals, plastics, hydraulic oil, etc. Dispose of these materials as industrial waste. Hydraulic oil, in particular, must be disposed of as per applicable statutory and regulatory requirements. Ensure proper disposal in accordance with applicable laws and regulations.

17 Warranty

We warrant the products manufactured by Sugiyasu Corporation to be free from defects in workmanship and material for 5 years.

Our obligation under this warranty is limited to repair or replacement, at our option, of any parts or material which, within this warranty period, are found to our satisfaction to be defective.

The belows are not covered by the warranty.

1. The damage or trouble caused by the false operation, negligence of the maintenance and storage required.
2. The damage or trouble caused by the modification that affects the originally designed functions.
3. Any consumable parts that need to be replaced.
4. The damage or trouble caused by natural disaster such as fire, earthquake, flood etc.
5. The damage or trouble caused by not using the original manufacturer's parts.
6. The required information such as serial No. etc. would not be provided.
7. The damage or trouble caused by improper installation.

- ※ Any consumable parts such as rubber parts etc. are not covered under this warranty
- ※ As this lift is not weatherproof, trouble caused by corrosion, rust, short circuit from water are not covered under warranty.

How To Claim

Contact your lift supplier.

18 After service

Something is wrong.	Check in accordance with this manual.
Something is still wrong	Contact your supplier for repair.
Repair under the warranty period	Will be repaired in accordance with the warranty rules
Repair after the warranty period	Contact your supplier for repair.
Availability of spare parts	The spare parts is available for 8 years after discontinuing manufacturing.

Contact your supplier for any information regarding to the after service. When contacting your supplier, provide Model No., Serial No., purchase date, and conditions of trouble.

Record the above information in the table below for future inquiries.

Type		
Serial No.	No.	
Purchase date	Date	
Supplier	Name:	Contact person:
	Address:	Tel:
Installer	Name:	Contact person:
	Address:	Tel:
Trouble date and conditions	Date	
	Date	
	Date	



SUGIYASU CORPORATION

3-21, 4-CHOME, HONGO-CHO, TAKAHAMACITY, AICHI, JAPAN 444-1394

TEL 81-566-53-1126 FAX 81-566-53-1844

<http://www.bishamon.co.jp/>